

EVALUATION KIT  
AVAILABLE



# Offline and DC-DC PWM Controllers for High-Brightness LED Drivers

## General Description

The MAX16801A/B/MAX16802A/B high-brightness (HB) LED driver-control ICs contain all the circuitry required for the design of wide-input-voltage-range LED drivers for general lighting and display applications. The MAX16801 is well suited for universal input (rectified 85VAC to 265VAC) LED drivers, while the MAX16802 is intended for low-input-voltage (10.8VDC to 24VDC) LED drivers.

When the LED current needs to be tightly regulated, an additional on-board error amplifier with 1% accurate reference can be utilized. A wide dimming range can be implemented by using low-frequency PWM dimming.

The MAX16801/MAX16802 feature an input undervoltage lockout (UVLO) for programming the input-supply start voltage, and to ensure proper operation during brownout conditions. The MAX16801 has an internal-bootstrap undervoltage lockout circuit with a large hysteresis that simplifies offline LED driver designs. The MAX16802 does not have this internal bootstrap circuit and can be biased directly from a +12V rail.

The 262kHz fixed switching frequency is internally trimmed, allowing for optimization of the magnetic and filter components, resulting in a compact, cost-effective LED driver. The MAX16801A/MAX16802A are offered with 50% maximum duty cycle. The MAX16801B/MAX16802B are offered with 75% maximum duty cycle. These devices are available in an 8-pin  $\mu$ MAX<sup>®</sup> package and operate over the -40°C to +85°C temperature range.

## Applications

Offline and DC-DC LED Drivers	Commercial and Industrial Lighting
RGB Back Light for LCD TVs and Monitors	Decorative and Architectural Lighting

$\mu$ MAX is a registered trademark of Maxim Integrated Products, Inc.

## Features

- ◆ Suitable for Buck, Boost, Flyback, SEPIC, and Other Topologies
- ◆ Up to 50W or Higher Output Power
- ◆ Universal Offline Input Voltage Range: Rectified 85VAC to 265VAC (MAX16801)
- ◆ IN Pin Directly Driven From 10.8VDC to 24VDC Input (MAX16802)
- ◆ Internal Error Amplifier with 1% Accurate Reference for Precise LED Current Regulation
- ◆ PWM or Linear Dimming
- ◆ Fixed Switching Frequency of 262kHz  $\pm$ 12%
- ◆ Thermal Shutdown
- ◆ Digital Soft-Start
- ◆ Programmable Input Startup Voltage
- ◆ Internal Bootstrap UVLO with Large Hysteresis (MAX16801)
- ◆ 45 $\mu$ A (typ) Startup Supply Current, 1.4mA (typ) Operating Supply Current
- ◆ 50% (MAX16801A/MAX16802A) or 75% (MAX16801B/MAX16802B) Maximum Duty Cycle
- ◆ Available in a Tiny 8-Pin  $\mu$ MAX Package

## Ordering Information

PART	TEMP RANGE	PIN-PACKAGE
MAX16801AEUA+	-40°C to +85°C	8 $\mu$ MAX
MAX16801BEUA+	-40°C to +85°C	8 $\mu$ MAX
MAX16802AEUA+	-40°C to +85°C	8 $\mu$ MAX
MAX16802BEUA+	-40°C to +85°C	8 $\mu$ MAX

+Denotes lead-free package.

## Typical Operating Circuit

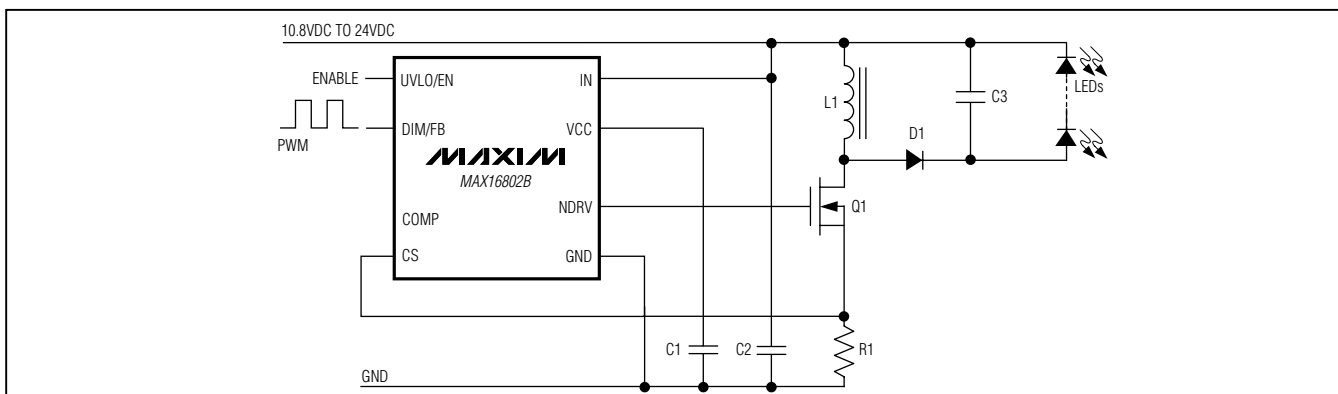

**Warning:** The MAX16801/MAX16802 are designed to work with high voltages. Exercise caution.



Maxim Integrated Products 1

For pricing, delivery, and ordering information, please contact Maxim/Dallas Direct! at 1-888-629-4642, or visit Maxim's website at [www.maxim-ic.com](http://www.maxim-ic.com).

MAX16801A/B/MAX16802A/B

# Offline and DC-DC PWM Controllers for High-Brightness LED Drivers

## ABSOLUTE MAXIMUM RATINGS

IN to GND	-0.3V to +30V
VCC to GND	-0.3V to +13V
DIM/FB, COMP, UVLO, CS to GND	-0.3V to +6V
NDRV to GND	-0.3V to (VCC + 0.3V)
Continuous Power Dissipation (T <sub>A</sub> = +70°C)	
8-Pin μMAX (derate 4.5mW/°C above +70°C)	362mW

Operating Temperature Range	-40°C to +85°C
Storage Temperature Range	-65°C to +150°C
Junction Temperature	+150°C
Lead Temperature (soldering, 10s)	+300°C

Stresses beyond those listed under "Absolute Maximum Ratings" may cause permanent damage to the device. These are stress ratings only, and functional operation of the device at these or any other conditions beyond those indicated in the operational sections of the specifications is not implied. Exposure to absolute maximum rating conditions for extended periods may affect device reliability.

## ELECTRICAL CHARACTERISTICS

(V<sub>IN</sub> = +12V (MAX16801: V<sub>IN</sub> must first be brought up to +23.6V for startup), 10nF bypass capacitors at IN and VCC, C<sub>NDRV</sub> = 0, V<sub>UVLO</sub> = +1.4V, V<sub>DIM/FB</sub> = +1.0V, COMP = unconnected, V<sub>CS</sub> = 0V, T<sub>A</sub> = -40°C to +85°C, unless otherwise noted. Typical values are at T<sub>A</sub> = +25°C.) (Note 1)

PARAMETER	SYMBOL	CONDITIONS	MIN	TYP	MAX	UNITS
<b>UNDERVOLTAGE LOCKOUT/STARTUP</b>						
Bootstrap UVLO Wake-Up Level	V <sub>SUVR</sub>	V <sub>IN</sub> rising (MAX16801 only)	19.68	21.6	23.60	V
Bootstrap UVLO Shutdown Level	V <sub>SUVF</sub>	V <sub>IN</sub> falling (MAX16801 only)	9.05	9.74	10.43	V
UVLO/EN Wake-Up Threshold	V <sub>ULR2</sub>	UVLO/EN rising	1.188	1.28	1.371	V
UVLO/EN Shutdown Threshold	V <sub>ULF2</sub>	UVLO/EN falling	1.168	1.23	1.291	V
UVLO/EN Input Current	I <sub>UVLO</sub>	T <sub>J</sub> = +125°C		25		nA
UVLO/EN Hysteresis				50		mV
IN Supply Current In Undervoltage Lockout	I <sub>START</sub>	V <sub>IN</sub> = +19V, for MAX16801 only when in bootstrap UVLO		45	90	μA
IN Voltage Range	V <sub>IN</sub>		10.8		24	V
UVLO/EN Propagation Delay	t <sub>EXTR</sub>	UVLO/EN steps up from +1.1V to +1.4V		12		μs
	t <sub>EXTF</sub>	UVLO/EN steps down from +1.4V to +1.1V		1.8		
Bootstrap UVLO Propagation Delay	t <sub>BUVR</sub>	V <sub>IN</sub> steps up from +9V to +24V		5		μs
	t <sub>BUVF</sub>	V <sub>IN</sub> steps down from +24V to +9V		1		
<b>INTERNAL SUPPLY</b>						
VCC Regulator Set Point	V <sub>CCSP</sub>	V <sub>IN</sub> = +10.8V to +24V, sinking 1μA to 20mA from VCC	7		10.5	V
IN Supply Current After Startup	I <sub>IN</sub>	V <sub>IN</sub> = +24V		1.4	2.5	mA
Shutdown Supply Current		UVLO/EN = low			90	μA
<b>GATE DRIVER</b>						
Driver Output Impedance	R <sub>ON(LOW)</sub>	Measured at NDRV sinking, 100mA		2	4	Ω
	R <sub>ON(HIGH)</sub>	Measured at NDRV sourcing, 20mA		4	12	
Driver Peak Sink Current				1		A
Driver Peak Source Current				0.65		A
<b>PWM COMPARATOR</b>						
Comparator Offset Voltage	V <sub>OPWM</sub>	V <sub>COMP</sub> - V <sub>CS</sub>	1.15	1.38	1.70	V
CS Input Bias Current	I <sub>CS</sub>	V <sub>CS</sub> = 0V	-2		+2	μA
Comparator Propagation Delay	t <sub>PWM</sub>	V <sub>CS</sub> = +0.1V		60		ns
Minimum On-Time	t <sub>ON(MIN)</sub>			150		ns

# Offline and DC-DC PWM Controllers for High-Brightness LED Drivers

MAX16801A/B/MAX16802A/B

## ELECTRICAL CHARACTERISTICS (continued)

( $V_{IN} = +12V$  (MAX16801:  $V_{IN}$  must first be brought up to +23.6V for startup), 10nF bypass capacitors at IN and VCC,  $C_{NDRV} = 0$ ,  $V_{UVLO} = +1.4V$ ,  $V_{DIM/FB} = +1.0V$ , COMP = unconnected,  $V_{CS} = 0V$ ,  $T_A = -40^{\circ}C$  to  $+85^{\circ}C$ , unless otherwise noted. Typical values are at  $T_A = +25^{\circ}C$ .) (Note 1)

PARAMETER	SYMBOL	CONDITIONS	MIN	TYP	MAX	UNITS
<b>CURRENT-SENSE COMPARATOR</b>						
Current-Sense Trip Threshold	$V_{CS}$		262	291	320	mV
CS Input Bias Current	$I_{CS}$	$V_{CS} = 0V$	-2		+2	$\mu A$
Propagation Delay From Comparator Input to NDRV	$t_{PWM}$	50mV overdrive		60		ns
Switching Frequency	$f_{SW}$		230	262	290	kHz
Maximum Duty Cycle	$D_{MAX}$	MAX1680_A		50	50.5	%
		MAX1680_B		75	76	
<b>IN CLAMP VOLTAGE</b>						
IN Clamp Voltage	$V_{INC}$	2mA sink current, MAX16801 only (Note 3)	24.1	26.1	29.0	V
<b>ERROR AMPLIFIER</b>						
Voltage Gain		$R_{LOAD} = 100k\Omega$		80		dB
Unity-Gain Bandwidth		$R_{LOAD} = 100k\Omega$ , $C_{LOAD} = 200pF$		2		MHz
Phase Margin		$R_{LOAD} = 100k\Omega$ , $C_{LOAD} = 200pF$		65		degrees
DIM/FB Input Offset Voltage					3	mV
COMP Clamp Voltage		High	2.2		3.5	V
		Low	0.4		1.1	
Source Current			0.5			mA
Sink Current			0.5			mA
Reference Voltage	$V_{REF}$	(Note 2)	1.218	1.230	1.242	V
Input Bias Current					50	nA
COMP Short-Circuit Current				8		mA
<b>THERMAL SHUTDOWN</b>						
Thermal-Shutdown Temperature				130		$^{\circ}C$
Thermal Hysteresis				25		$^{\circ}C$
<b>DIGITAL SOFT-START</b>						
Soft-Start Duration				15,872		clock cycles
Reference Voltage Steps During Soft-Start				31		steps
Reference Voltage Step				40		mV

**Note 1:** All devices are 100% tested at  $T_A = +85^{\circ}C$ . All limits over temperature are guaranteed by characterization.

**Note 2:**  $V_{REF}$  is measured with DIM/FB connected to the COMP pin (see the *Functional Diagram*).

**Note 3:** The MAX16801 is intended for use in universal input offline drivers. The internal clamp circuit is used to prevent the bootstrap capacitor (C1 in Figure 5) from charging to a voltage beyond the absolute maximum rating of the device when EN/UVLO is low. The maximum current to IN (hence to clamp) when UVLO is low (device in shutdown), must be externally limited to 2mA (max). Clamp currents higher than 2mA may result in clamp voltage higher than +30V, thus exceeding the absolute maximum rating for IN. For the MAX16802, do not exceed the +24V maximum operating voltage of the device.

# Offline and DC-DC PWM Controllers for High-Brightness LED Drivers

## Typical Operating Characteristics

( $V_{UVLO/EN} = +1.4V$ ,  $V_{FB} = +1V$ , COMP = unconnected,  $V_{CS} = 0V$ ,  $T_A = +25^\circ C$ , unless otherwise noted.)

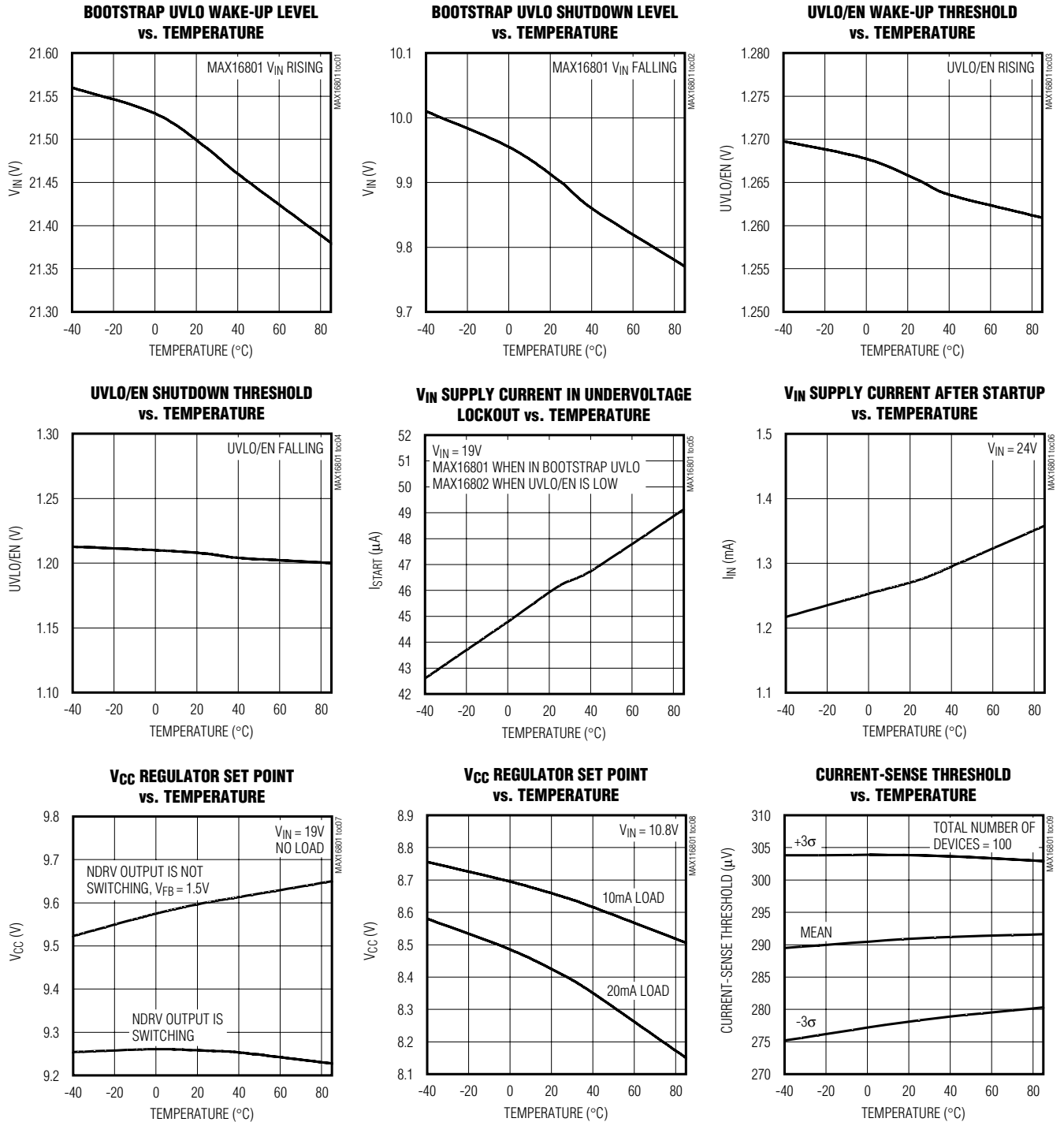

# Offline and DC-DC PWM Controllers for High-Brightness LED Drivers

## Typical Operating Characteristics (continued)

( $V_{UVLO/EN} = +1.4V$ ,  $V_{FB} = +1V$ , COMP = unconnected,  $V_{CS} = 0V$ ,  $T_A = +25^\circ C$ , unless otherwise noted.)

MAX16801A/B/MAX16802A/B

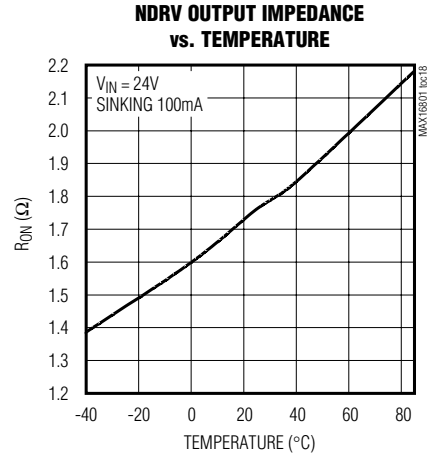
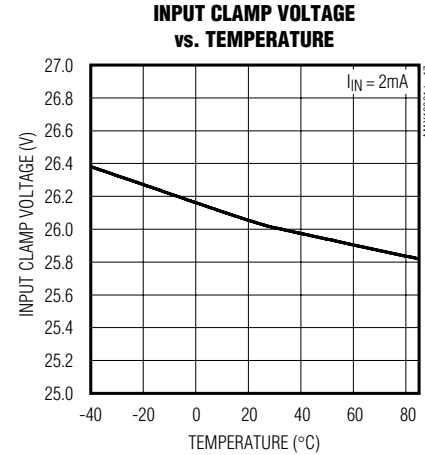
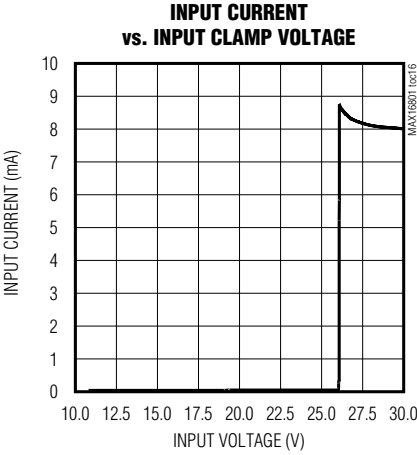
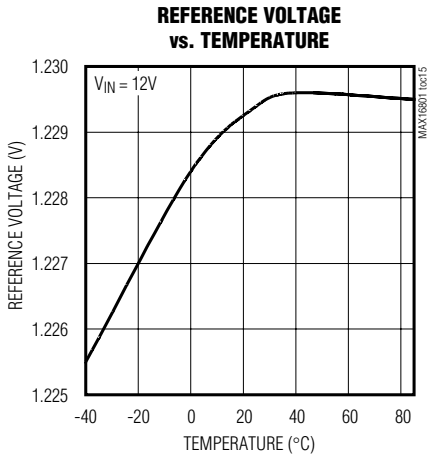
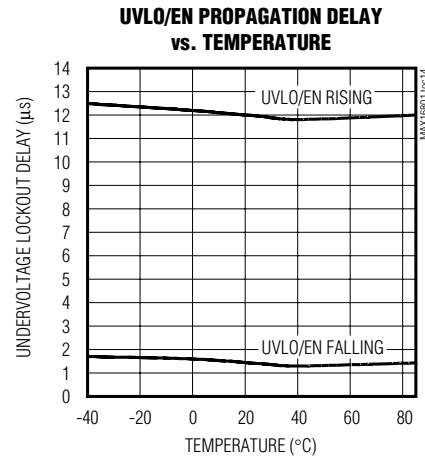
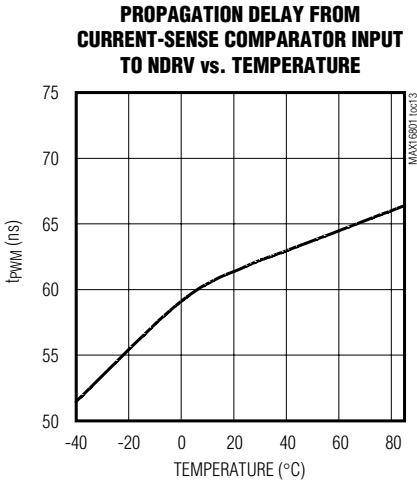
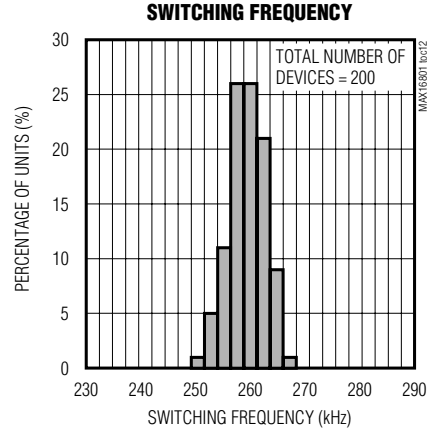
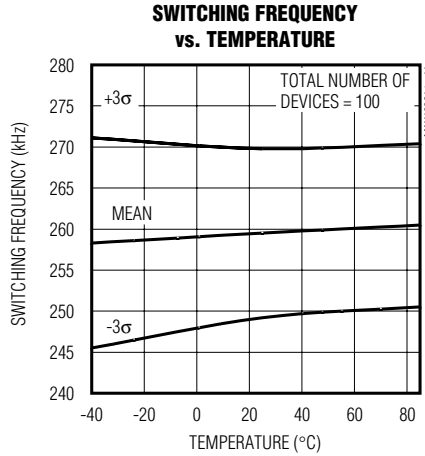
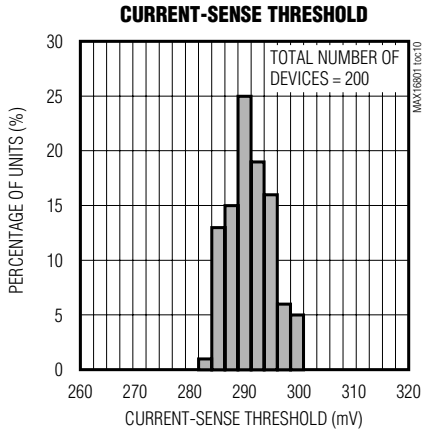

# Offline and DC-DC PWM Controllers for High-Brightness LED Drivers

## Typical Operating Characteristics (continued)

( $V_{UVLO/EN} = +1.4V$ ,  $V_{FB} = +1V$ , COMP = unconnected,  $V_{CS} = 0V$ ,  $T_A = +25^\circ C$ , unless otherwise noted.)

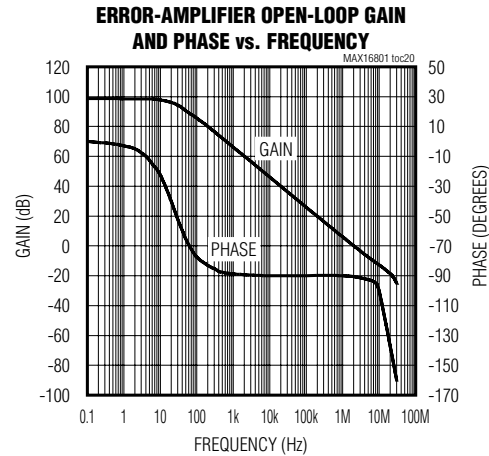
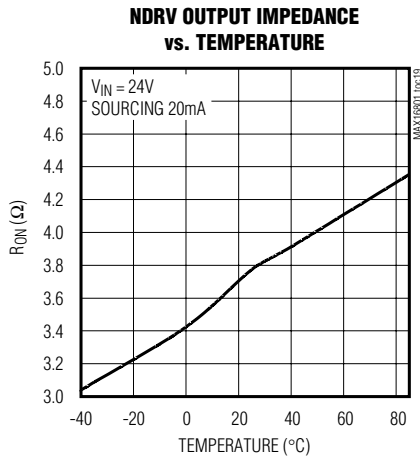

## Pin Description

PIN	NAME	FUNCTION
1	UVLO/EN	Externally Programmable Undervoltage Lockout. UVLO programs the input start voltage. Connect UVLO to GND to disable the device.
2	DIM/FB	Low-Frequency PWM Dimming Input/Error-Amplifier Inverting Input
3	COMP	Error-Amplifier Output. Connect the compensation components between DIM/FB and COMP in high-accuracy LED current regulation.
4	CS	Current-Sense Connection for Current Regulation. Connect to high side of sense resistor. An RC filter may be necessary to eliminate leading-edge spikes.
5	GND	Power-Supply Ground
6	NDRV	External n-Channel MOSFET Gate Connection
7	VCC	Gate-Drive Supply. Internally regulated down from IN. Decouple with a 10nF or larger capacitor to GND.
8	IN	IC Supply. Decouple with a 10nF or larger capacitor to GND. For bootstrapped operation (MAX16801), connect a startup resistor from the input supply line to IN. Connect the bias winding supply to this point (see Figure 5). For the MAX16802, connect IN directly to a +10.8V to +24V supply.

## Detailed Description

The MAX16801/MAX16802 family of devices is intended for constant current drive of high-brightness (HB) LEDs used in general lighting and display applications. They are specifically designed for use in isolated and nonisolated circuit topologies such as buck, boost, fly-back, and SEPIC, operating in continuous or discontinuous mode. Current mode control is implemented with an internally trimmed, fixed 262kHz switching frequency. A bootstrap UVLO with a large hysteresis (11.9V), very low startup current, and low operating current

result in an efficient universal-input LED driver. In addition to the internal bootstrap UVLO, these devices also offer programmable input startup voltage programmed through the UVLO/EN pin. The MAX16801 is well suited for universal AC input (rectified 85VAC to 265VAC) drivers. The MAX16802 is well suited for low input voltage (10.8VDC to 24VDC) applications.

The MAX16801/MAX16802 regulate the LED current by monitoring current through the external MOSFET cycle by cycle.

# Offline and DC-DC PWM Controllers for High-Brightness LED Drivers

When in the bootstrapped mode with a transformer (Figure 5), the circuit is protected against most output short-circuit faults when the tertiary voltage drops below +10V, causing the UVLO to turn off the gate drive of the external MOSFET. This re-initiates a startup sequence with soft-start.

When the LED current needs to be tightly regulated, an internal error amplifier with 1% accurate reference can be used (Figure 9). This additional feedback minimizes the impact of passive circuit component variations and tolerances, and can be implemented with a minimum number of additional external components.

A wide dimming range can be implemented using a low-frequency PWM dimming signal fed directly to the DIM/FB pin.

LED driver circuits designed with the MAX16801 use a high-value startup resistor R1 that charges a reservoir capacitor C1 (Figure 5 or Figure 9). During this initial period, while the voltage is less than the internal bootstrap UVLO threshold, the device typically consumes only 45 $\mu$ A of quiescent current. This low startup current and the large bootstrap UVLO hysteresis help minimize

the power dissipation across R1, even at the high end of the universal AC input voltage.

An internal shutdown circuit protects the device whenever the junction temperature exceeds +130°C (typ).

### Dimming

Linear dimming can be implemented by creating a summing node at CS, as shown in Figures 6 and 7.

Low-frequency PWM (chopped-current) dimming is possible by applying an inverted-logic PWM signal to the DIM/FB pin of the IC (Figure 8). This might be a preferred way of dimming in situations where it is critical to retain the light spectrum unchanged. It is accomplished by keeping constant the amplitude of the chopped LED current.

### MAX16801/MAX16802 Biasing

Implement bootstrapping from the transformer when it is present (Figure 5). Biasing can also be realized directly from the LEDs in non-isolated topologies (Figure 1).

Bias the MAX16802 directly from the input voltage of 10.8VDC to 24VDC. The MAX16802 can also be used

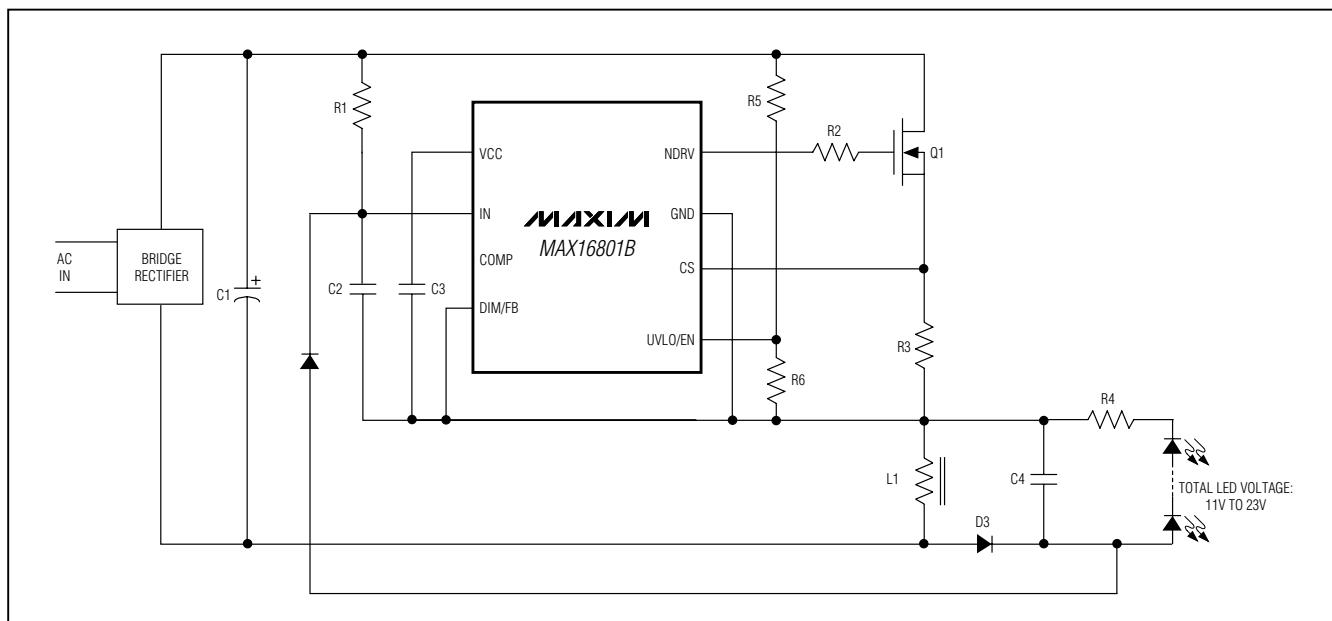

Figure 1. Biasing the IC using LEDs in Nonisolated Flyback Driver

# Offline and DC-DC PWM Controllers for High-Brightness LED Drivers

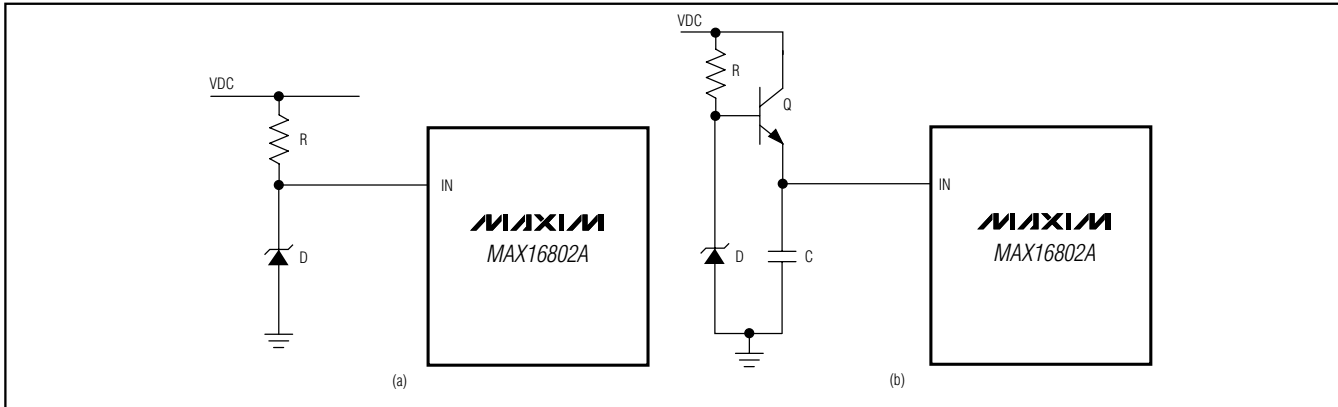

Figure 2. (a) Resistor-Zener and (b) Transistor-Zener-Resistor Bias Arrangements

in applications with higher input DC voltages by implementing resistor-Zener bias (Figure 2a) or transistor-Zener-resistor bias (Figure 2b).

## MAX16801/MAX16802 Undervoltage Lockout

The MAX16801/MAX16802 have an input voltage UVLO/EN pin. The threshold of this UVLO is +1.28V. Before any operation can commence, the voltage on this pin has to exceed +1.28V. The UVLO circuit keeps the CPWM comparator, ILIM comparator, oscillator, and output driver in shutdown to reduce current consumption (see the *Functional Diagram*). Use this UVLO function to program the input start voltage. Calculate the divider resistor values, R2 and R3 (Figure 5), by using the following formulas:

$$R3 \cong \frac{V_{ULR2} \times V_{IN}}{500 \times I_{UVLO}(V_{IN} - V_{ULR2})}$$

The value of R3 is calculated to minimize the voltage-drop error across R2 as a result of the input bias current of the UVLO/EN pin.  $V_{ULR2} = +1.28V$ ,  $I_{UVLO} = 50nA$  (max),  $V_{IN}$  is the value of the input-supply voltage where the power supply must start.

$$R2 = \frac{V_{IN} - V_{ULR2}}{V_{ULR2}} \times R3$$

where  $I_{UVLO}$  is the UVLO/EN pin input current, and  $V_{ULR2}$  is the UVLO/EN wake-up threshold.

## MAX16801 Bootstrap Undervoltage Lockout

In addition to the externally programmable UVLO function offered in both the MAX16801/MAX16802, the MAX16801 has an additional internal bootstrap UVLO that is very useful when designing high-voltage LED drivers (see the *Functional Diagram*). This allows the device to bootstrap itself during initial power-up. The MAX16801 attempts to start when  $V_{IN}$  exceeds the bootstrap UVLO threshold of +23.6V. During startup, the UVLO circuit keeps the CPWM comparator, ILIM comparator, oscillator, and output driver shut down to reduce current consumption. Once  $V_{IN}$  reaches +23.6V, the UVLO circuit turns on both the CPWM and ILIM comparators, as well as the oscillator, and allows the output driver to switch. If  $V_{IN}$  drops below +9.7V, the UVLO circuit will shut down the CPWM comparator, ILIM comparator, oscillator, and output driver thereby returning the MAX16801 to the startup mode.

## MAX16801 Startup Operation

In isolated LED driver applications,  $V_{IN}$  can be derived from a tertiary winding of a transformer. However, at startup there is no energy delivered through the transformer. Therefore, a special bootstrap sequence is required. Figure 3 shows the voltages on IN and VCC during startup. Initially, both  $V_{IN}$  and  $V_{CC}$  are 0V. After the line voltage is applied, C1 charges through the startup resistor R1 to an intermediate voltage. At this point, the internal regulator begins charging C2 (see Figure 5). The MAX16801 uses only 45 $\mu$ A of the current supplied by R1, and the remaining input current charges C1 and C2. The charging of C2 stops when the VCC voltage reaches approximately +9.5V, while the voltage across C1 continues rising until it reaches



# Offline and DC-DC PWM Controllers for High-Brightness LED Drivers

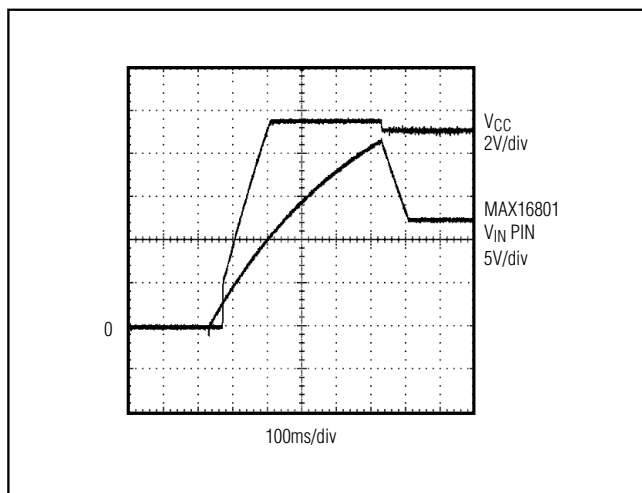

Figure 3.  $V_{IN}$  and  $V_{CC}$  During Startup when Using the MAX16801 in Bootstrapped Mode

the wake-up level of +23.6V. Once  $V_{IN}$  exceeds the bootstrap UVLO threshold, NDRV begins switching the MOSFET and transfers energy to the secondary and tertiary outputs. If the voltage on the tertiary output builds to a value higher than +9.7V (the bootstrap UVLO lower threshold), then startup has been accomplished and sustained operation commences.

If  $V_{IN}$  drops below +9.7V before startup is complete, the device goes back to low-current UVLO. In this case, increase C1 in order to store enough energy to allow for the voltage at the tertiary winding to build up.

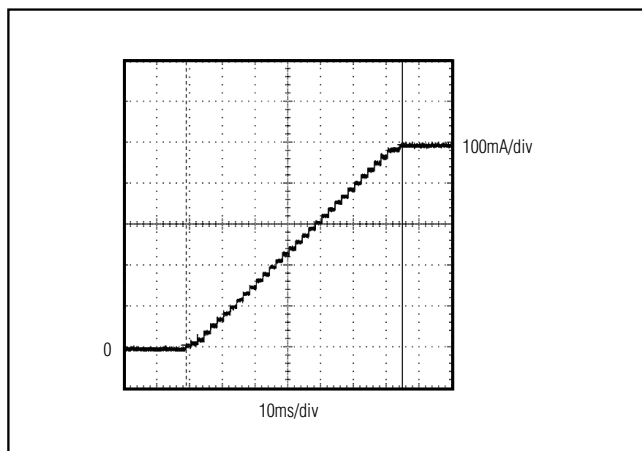

Figure 4. Typical Current Soft-Start During Initial Startup

## Soft-Start

The MAX16801/MAX16802 soft-start feature allows the LED current to ramp up in a controlled manner. Soft-start begins after UVLO deasserts. The voltage applied to the noninverting node of the amplifier ramps from 0 to +1.23V over a 60ms soft-start timeout period. Figure 4 shows a typical 0.5A output current during startup. Note the staircase increase of the LED current. This is a result of the digital soft-starting technique used. Unlike other devices, the reference voltage to the internal amplifier is soft-started. This method results in superior control of the LED current.

## n-Channel MOSFET Switch Driver

The NDRV pin drives an external n-channel MOSFET. The NDRV output is supplied by the internal regulator ( $V_{CC}$ ), which is internally set to approximately +9.5V. For the universal input voltage and applications with a transformer, the MOSFET used must be able to withstand the DC level of the high-line input voltage plus the reflected voltage at the primary of the transformer. For most offline applications that use the discontinuous flyback topology, this requires a MOSFET rated at 600V. NDRV can source/sink in excess of the 650mA/1000mA peak current. Select a MOSFET that yields acceptable conduction and switching losses.

## Internal Error Amplifier

The MAX16801/MAX16802 include an internal error amplifier that can be used to regulate the LED current very accurately. For example, see the nonisolated power supply in Figure 5. Calculate the LED current using the following equation:

$$I_{LED} = \frac{V_{REF}}{R7}$$

where  $V_{REF} = +1.23V$ . The amplifier's noninverting input is internally connected to a digital soft-start circuit that gradually increases the reference voltage during startup and is applied to this pin. This forces the LED current to come up in an orderly and well-defined manner under all conditions.

# Offline and DC-DC PWM Controllers for High-Brightness LED Drivers

## Applications Information

### Startup Time Considerations for High-Brightness LED Drivers Using MAX16801

The IN bypass capacitor C1 supplies current immediately after wake-up (Figure 5). The size of C1 and the connection configuration of the tertiary winding determine the number of cycles available for startup. Large values of C1 increase the startup time but also supply gate charge for more cycles during initial startup. If the value of C1 is too small,  $V_{IN}$  drops below +9.7V because NDRV does not have enough time to switch and build up sufficient voltage across the tertiary winding that powers the device. The device goes back into UVLO and does not start. Use low-leakage capacitors for C1 and C2.

Assuming that offline LED drivers keep typical startup times to less than 500ms even in low-line conditions (85VAC input for universal offline applications), size the startup resistor R1 to supply both the maximum startup bias of the device (90 $\mu$ A, worst case) and the charging current for C1 and C2. The bypass capacitor C2 must charge to +9.5V and C1 to +24V, all within the desired time period of 500ms.

Because of the internal 60ms soft-start time of the MAX16801, C1 must store enough charge to deliver current to the device for at least this much time. To calculate the approximate amount of capacitance required, use the following formula:

$$I_g = Q_{gtot} \times f_{sw}$$

$$C1 = \frac{(I_{IN} + I_g)(t_{SS})}{V_{HYST}}$$

where  $I_{IN}$  is the MAX16801's internal supply current after startup (1.4mA),  $Q_{gtot}$  is the total gate charge for Q1,  $f_{sw}$  is the MAX16801's switching frequency (262kHz),  $V_{HYST}$  is the bootstrap UVLO hysteresis (11.9V) and  $t_{SS}$  is the internal soft-start time (60ms).

For example:

$$I_g = (8nC) \times (262kHz) = 2.1mA$$

$$C1 = \frac{(1.4mA + 2.1mA) \times (60ms)}{(12V)} = 17.5\mu F$$

Choose the 15 $\mu$ F standard value.

Assuming  $C1 > C2$ , calculate the value of R1 as follows:

$$I_{C1} = \frac{V_{SUVR} \times C1}{(500ms)}$$

$$R1 = \frac{V_{IN(MIN)} - V_{SUVR}}{I_{C1} + I_{START}}$$

where  $V_{IN(MIN)}$  is the minimum input supply voltage for the application,  $V_{SUVR}$  is the bootstrap UVLO wake-up level (+23.6V, max), and  $I_{START}$  is the IN supply current at startup (90 $\mu$ A, max).

For example, for the minimum AC input of 85V:

$$I_{C1} = \frac{(24V) - (12V)}{(500ms)} = 0.72mA$$

$$R1 = \frac{(120V) \times (15\mu F)}{(0.72mA + (90\mu A))} = 133.4k\Omega$$

Choose the 150k $\Omega$  standard value.

Choose a higher value for R1 than the one calculated above if longer startup time can be tolerated in order to minimize power loss on this resistor.

The above startup method is applicable to a circuit similar to the one shown in Figure 5. In this circuit, the tertiary winding has the same phase as the output windings. Thus, the voltage on the tertiary winding at any given time is proportional to the output voltage and goes through the same soft-start period as the output voltage. The minimum discharge voltage of C1 from +22V to +10V must be greater than the soft-start time of 60ms.

Another method of bootstrapping the circuit is to have a separate bias winding than the one used for regulating the output voltage and to connect the bias winding so that it is in phase with the MOSFET ON time (see Figure 9). In this case, the amount of capacitance required is much smaller.

However, in this mode, the input voltage range has to be less than 2:1. Another consideration is whether the bias winding is in phase with the output. If so, the LED driver circuit hiccups and soft-starts under output short-circuit conditions. However, this property is lost if the bias winding is in phase with the MOSFET ON time.

# Offline and DC-DC PWM Controllers for High-Brightness LED Drivers

## Application Circuits

Figure 5 shows an offline application of an HB LED driver using the MAX16801. The use of transformer T1 allows significant design flexibility. Use the internal error amplifier for a very accurate LED current control.

Figure 6 shows a discontinuous flyback LED driver with linear dimming capability. The total LED voltage can be lower or higher than the input voltage.

Figure 7 shows a continuous-conduction-mode HB LED buck driver with linear dimming and just a few external components.

Figure 8 shows an offline isolated flyback HB LED driver with low-frequency PWM using MAX16801. The PWM signal needs to be inverted (see the *Functional Diagram*). Transformer T1 provides full safety isolation and operation from universal AC line (85VAC to 265VAC).

MAX16801A/B/MAX16802A/B

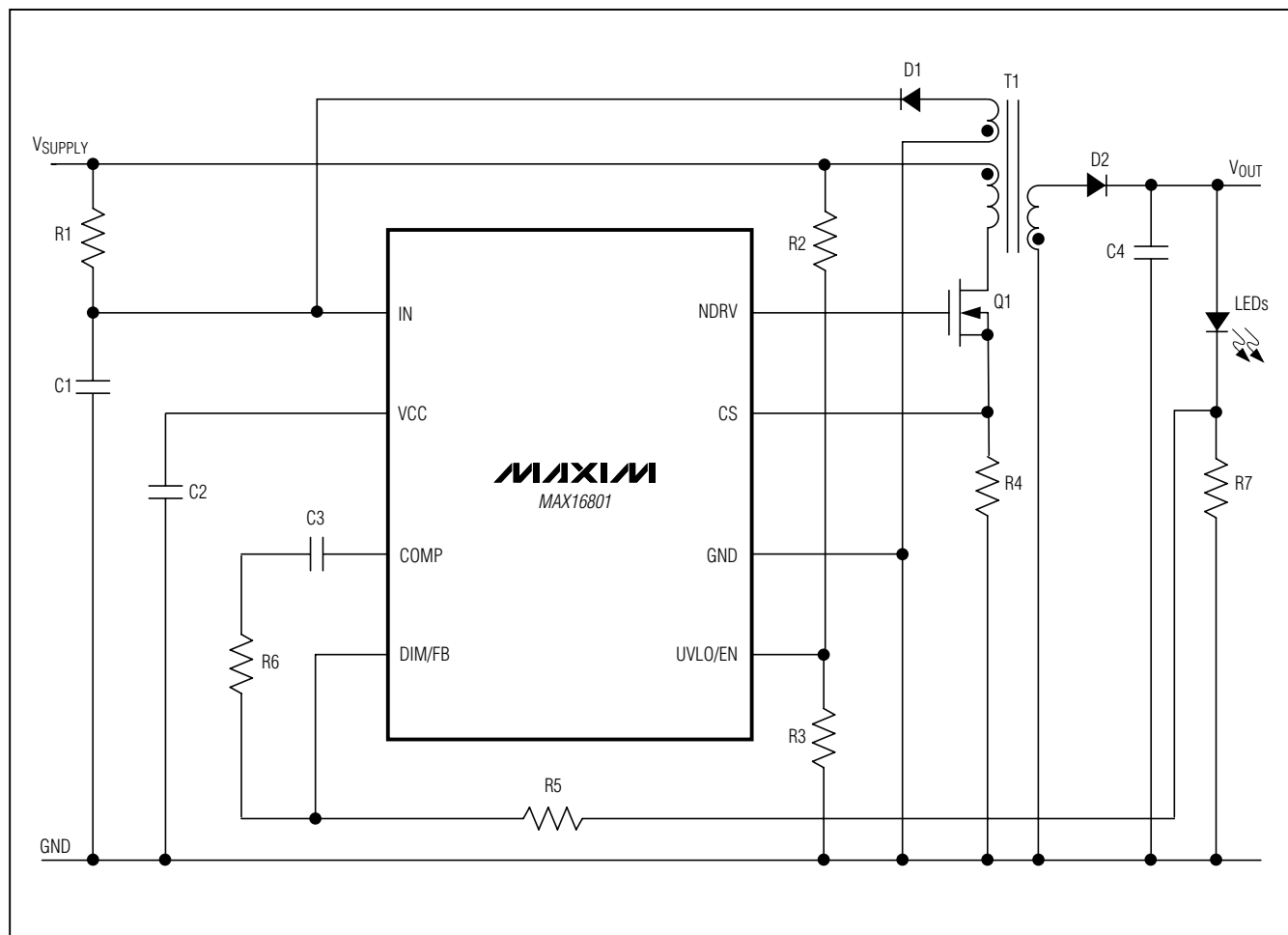

Figure 5. Offline, Nonisolated, Flyback LED Driver with Programmable Input-Supply Start Voltage

# Offline and DC-DC PWM Controllers for High-Brightness LED Drivers

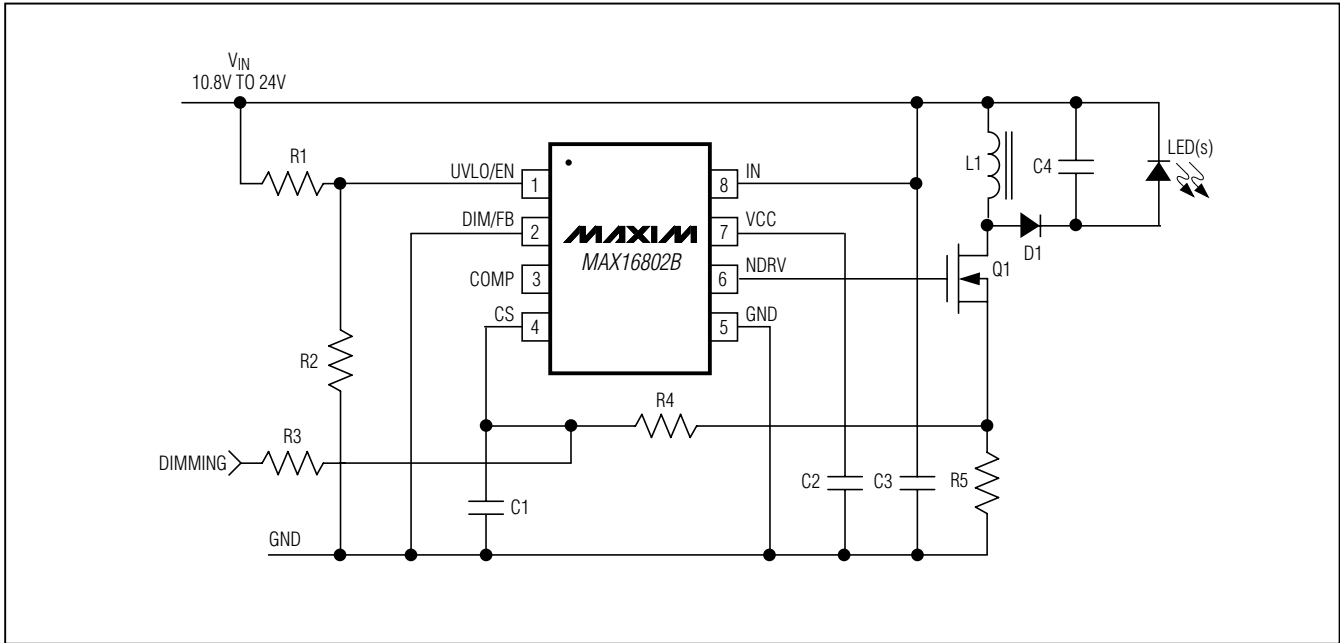

Figure 6. MAX16802 Flyback HB LED Driver with Dimming Capability, 10.8V to 24V Input Voltage Range

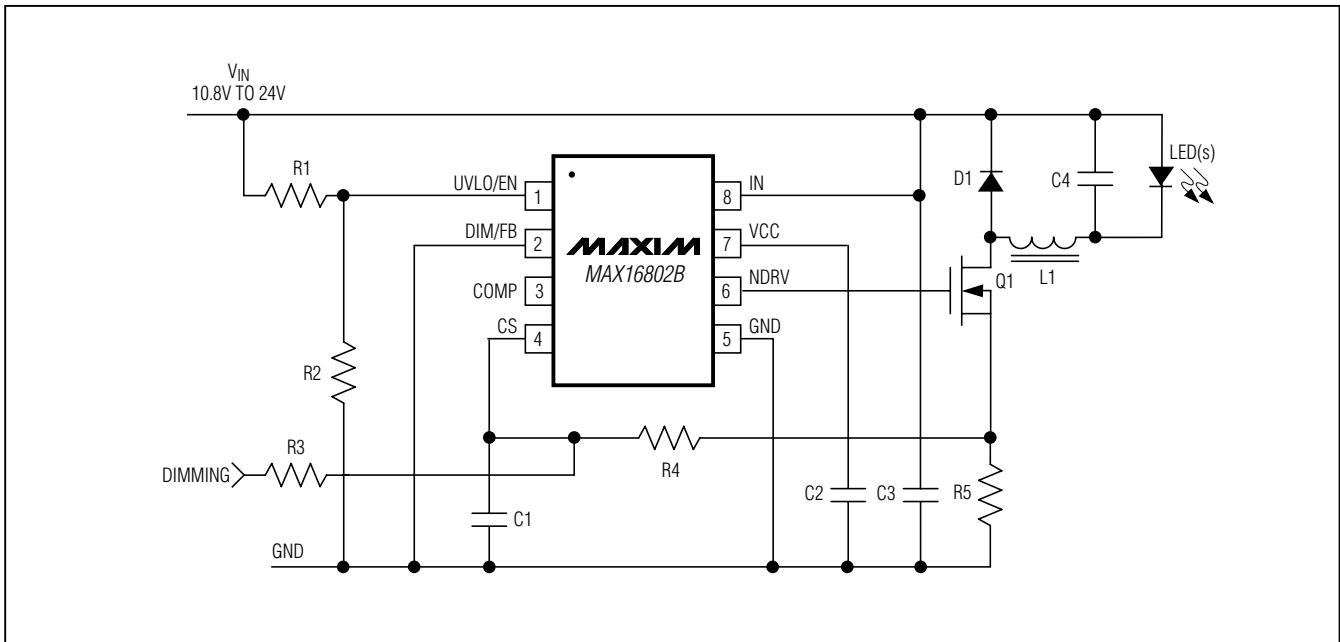

Figure 7. MAX16802 Buck HB LED Driver with Dimming Capability, 10.8V to 24V Input Voltage Range

# Offline and DC-DC PWM Controllers for High-Brightness LED Drivers

**MAX16801A/B/MAX16802A/B**

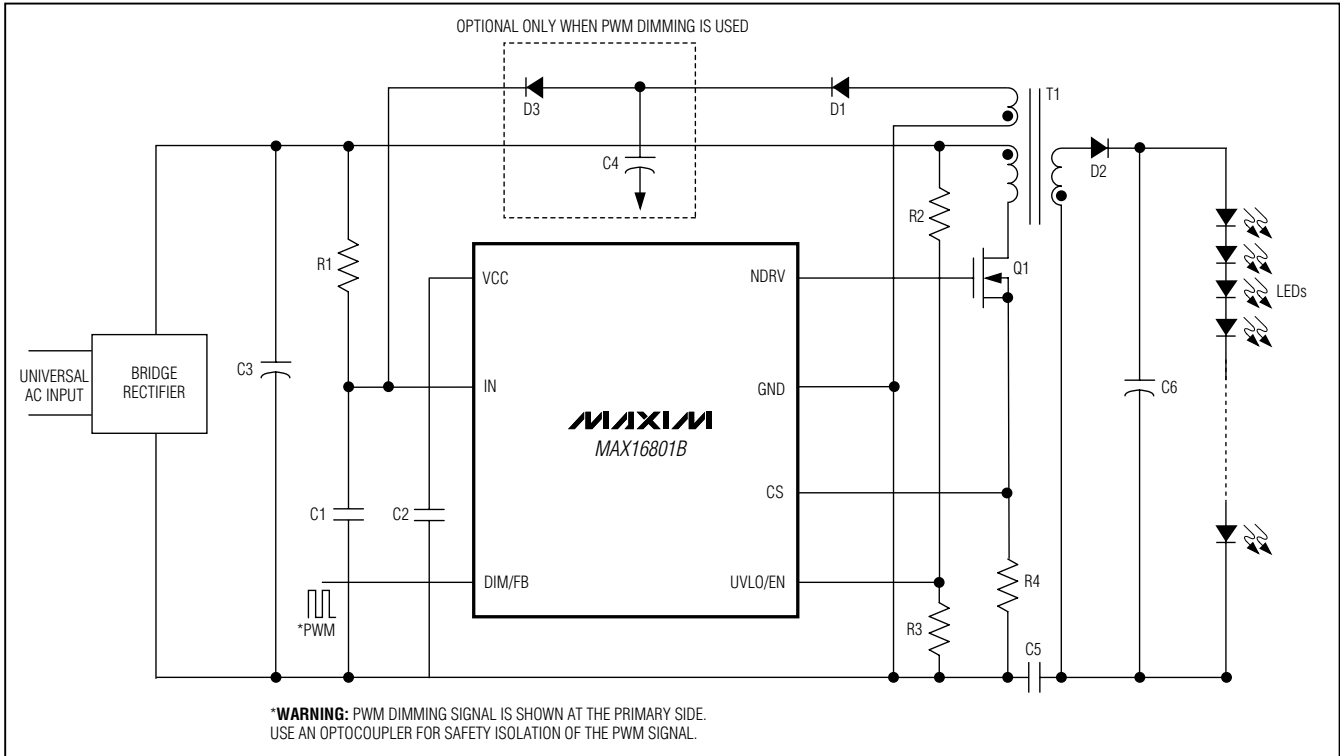

Figure 8. Universal AC Input, Offline, Isolated Flyback HB LED Driver with Low-Frequency PWM Dimming

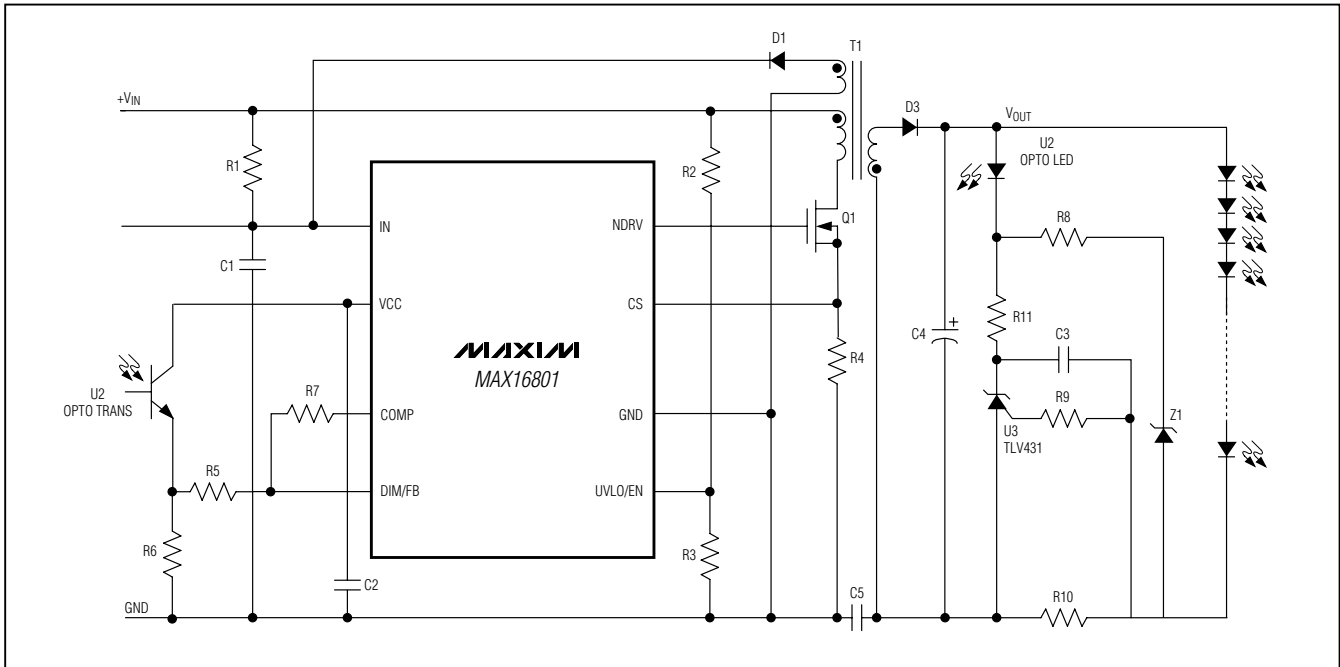
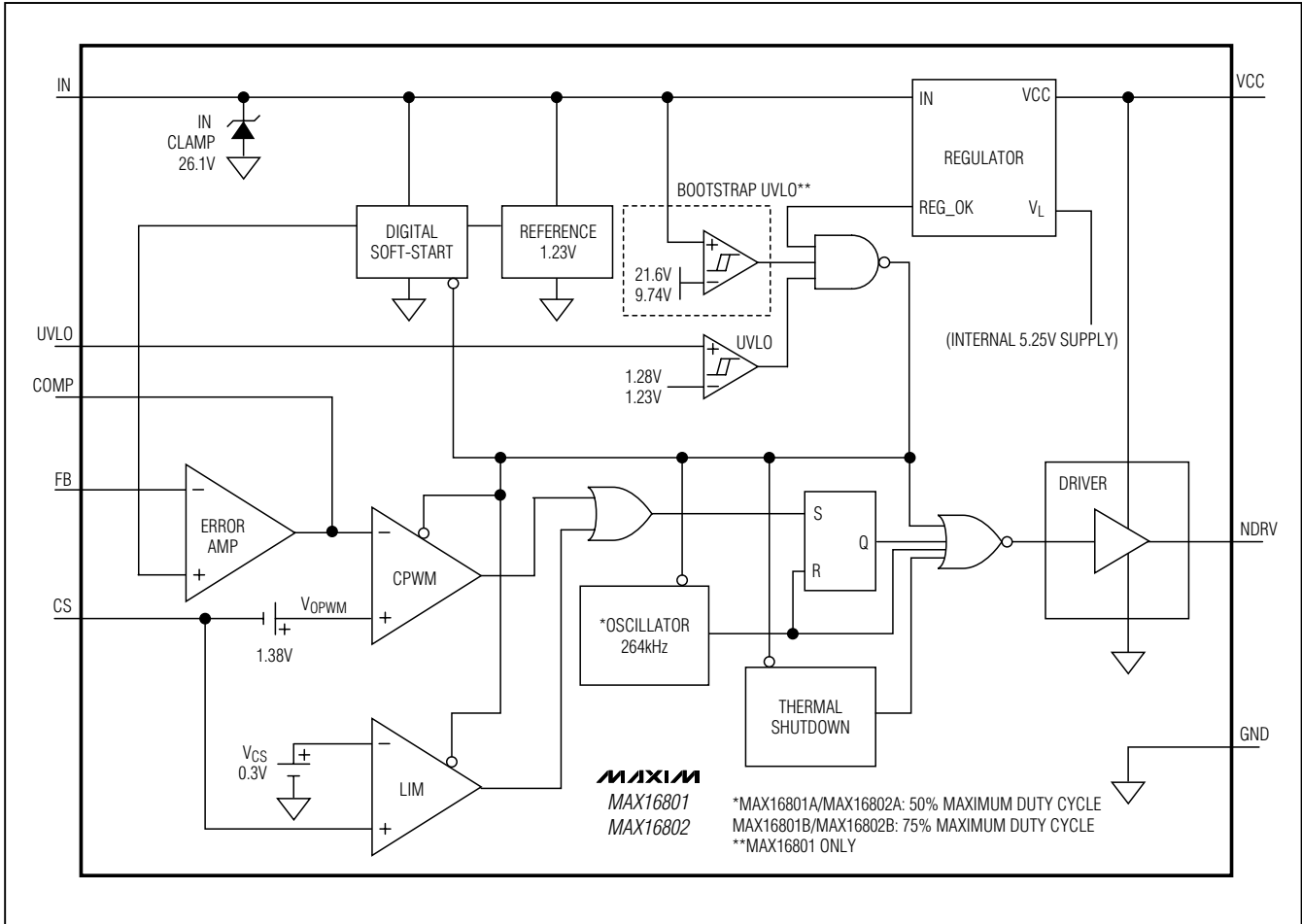

Figure 9. Universal Input, Offline, High-Accuracy Current Regulation in an Isolated Flyback HB LED Driver

# Offline and DC-DC PWM Controllers for High-Brightness LED Drivers

## Functional Diagram



## Selector Guide

PART	BOOTSTRAP UVLO	STARTUP VOLTAGE (V)	MAX DUTY CYCLE (%)
MAX16801A	Yes	22	50
MAX16801B	Yes	22	75
MAX16802A	No	10.8*	50
MAX16802B	No	10.8*	75

\*The MAX16802 does not have an internal bootstrap UVLO. The MAX16802 starts operation as long as the VCC pin is higher than +7V, (the guaranteed output with an IN pin voltage of +10.8V), and the UVLO/EN pin is high.

## Pin Configuration

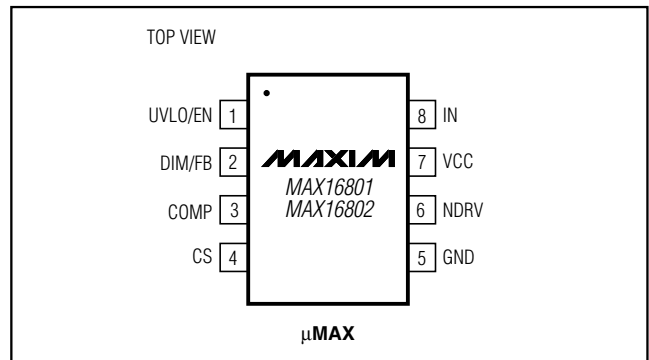

# Offline and DC-DC PWM Controllers for High-Brightness LED Drivers

## Package Information

(The package drawing(s) in this data sheet may not reflect the most current specifications. For the latest package outline information, go to [www.maxim-ic.com/packages](http://www.maxim-ic.com/packages).)

MAX16801A/B/MAX16802A/B

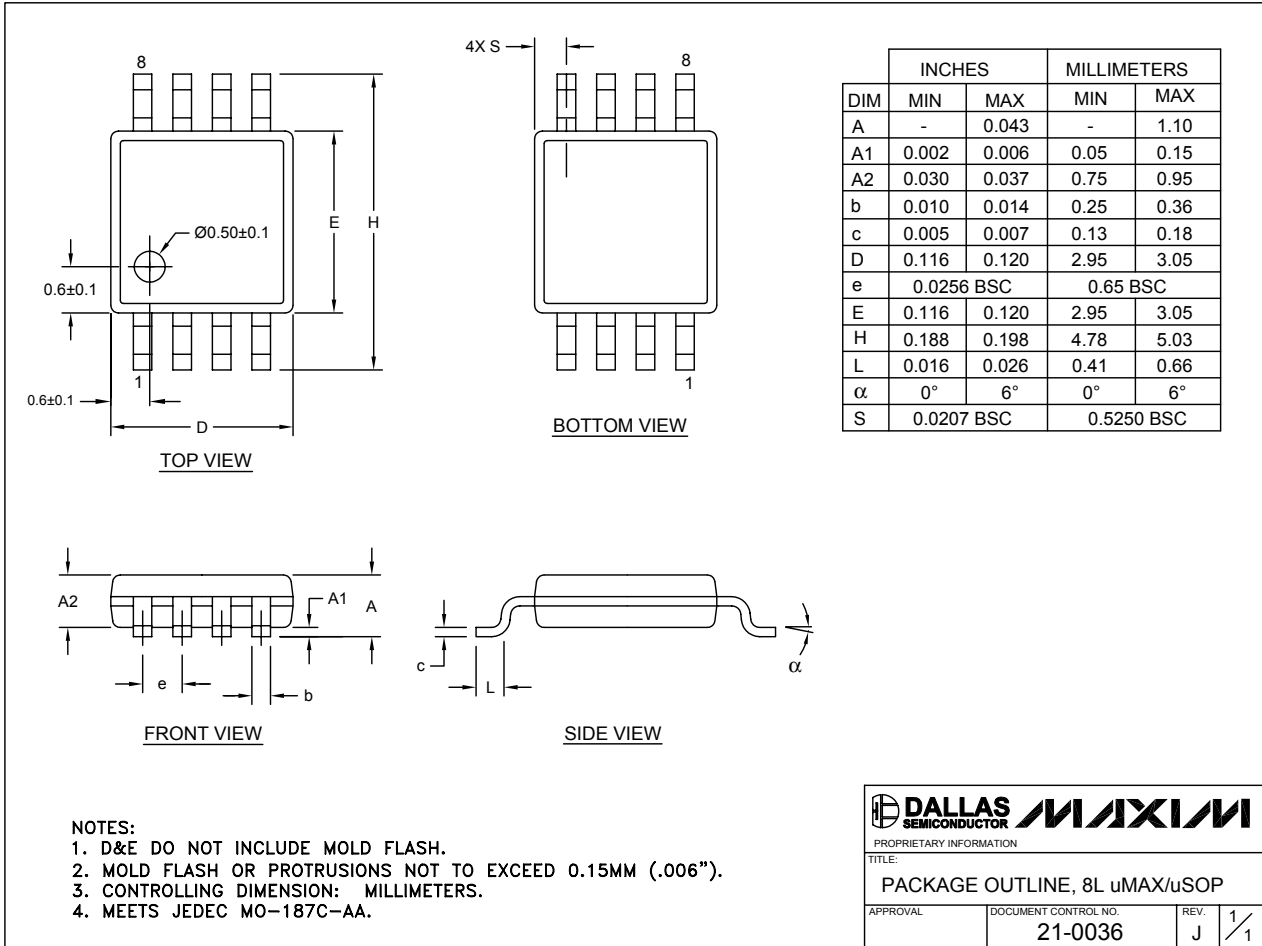

Maxim cannot assume responsibility for use of any circuitry other than circuitry entirely embodied in a Maxim product. No circuit patent licenses are implied. Maxim reserves the right to change the circuitry and specifications without notice at any time.

Maxim Integrated Products, 120 San Gabriel Drive, Sunnyvale, CA 94086 408-737-7600 15